

TOWER FOUNDATION

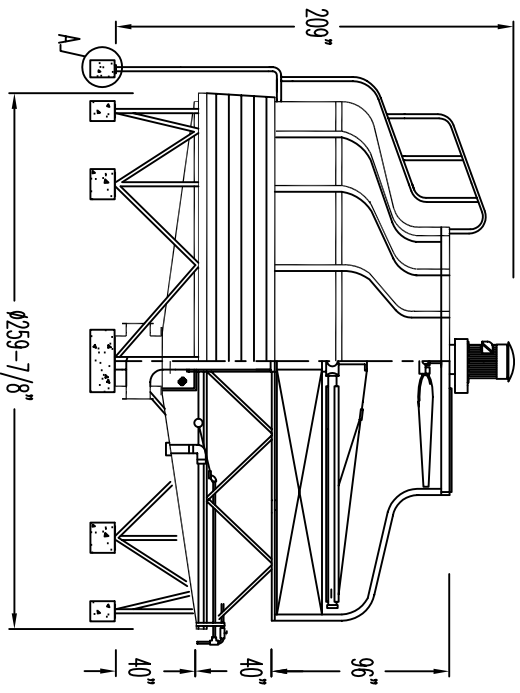

TOWER OVERALL DIMENSION

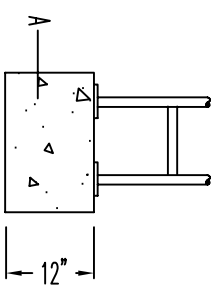
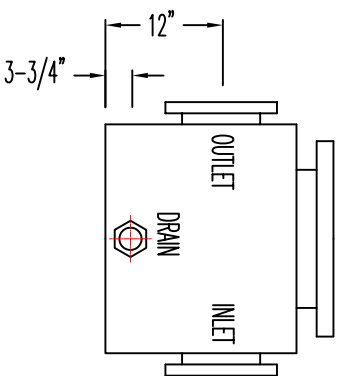

| | | |
|--------------------|-------------------|-------|
| TOWER WEIGHT(Lbs) | NET WEIGHT | 8690 |
| | OPERATING WEIGHT | 21193 |
| LOADING POINT(Lbs) | STAND | 1891 |
| | TANK | 6065 |
| PIPING | OUTLET | 10" |
| | INLET | 10" |
| | OVERFLOW | 4" |
| | DRAIN | 4" |
| | AUTOMATIC MAKE-UP | 2" |
| MANUAL MAKE-UP | 2" | |

- NOTES:
1. THE COOLING TOWER MUST BE LOCATED AT SUCH DISTANCE AND DIRECTION TO AVOID THE POSSIBILITY OF CONTAMINATED TOWER DISCHARGE AIR BEING DRAIN INTO BUILDING FRESH AIR INTAKES
 2. ANCHOR BOLT BY OTHERS.
 3. CONTINUING ENGINEERING RESEARCH RESULTS IN STEADY IMPROVEMENTS. THEREFORE, THESE SPECIFICATIONS AND DATA ARE SUBJECT TO CHANGE WITHOUT NOTICE. CONSULT WITH FACTORY FOR CURRENT CERTIFIED DIMENSIONS.

| | | | | |
|----------|--------|------------|------------------------------------|---------------------------------|
| APPROVED | KM LIN | 06/27/2007 | DWG TITLE: | TOWER DIMENSIONS AND FOUNDATION |
| CHECKED | NOJUN | 11/07/2007 | DWG DETAIL: | PCT-600 |
| DRAWN | HUANG | 06/27/2007 | DWG NO.: | AFP-0600-0 |
| ITEM | ZENG | 06/26/2007 | | DO NOT SCALE |
| | BY | DATE | PROTEC COOLING TOWERS, INC. | |