

TOWER FOUNDATION

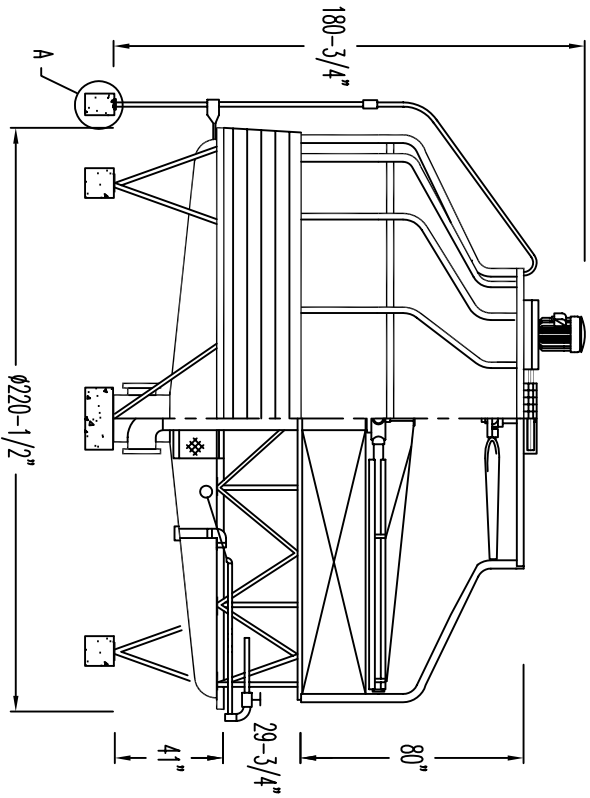

TOWER OVERALL DIMENSION

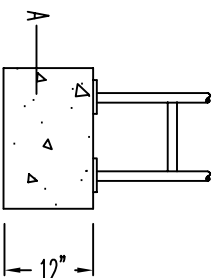
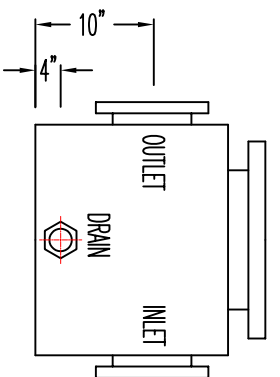

LOADING POINT(Lbs)	TOWER WEIGHT(Lbs)	
	NET WEIGHT	OPERATING WEIGHT
STAND	1802	15466
TANK	4658	
PIPING	OUTLET	10"
	INLET	10"
	OVERFLOW	4"
	DRAIN	4"
	AUTOMATIC MAKE-UP	2"
MANUAL MAKE-UP	2"	

- NOTES:
1. THE COOLING TOWER MUST BE LOCATED AT SUCH DISTANCE AND DIRECTION TO AVOID THE POSSIBILITY OF CONTAMINATED TOWER DISCHARGE AIR BEING DRAWN INTO BUILDING FRESH AIR INTAKES
 2. ANCHOR BOLT BY OTHERS.
 3. CONTINUING ENGINEERING RESEARCH RESULTS IN STEADY IMPROVEMENTS. THEREFORE, THESE SPECIFICATIONS AND DATA ARE SUBJECT TO CHANGE WITHOUT NOTICE. CONSULT WITH FACTORY FOR CURRENT CERTIFIED DIMENSIONS.

APPROVED	KM LIN	06.27.2007	DWG TITLE:	TOWER DIMENSIONS AND FOUNDATION	
CHECKED	NQUIN	11.07.2007	DWG DETAIL:	PCT-500	
DRAWN	HUANG	06.27.2007	DWG NO.:	AFP-0500-0	DO NOT SCALE
ITEM	ZENG	06.26.2007	BY	DATE	
PROTEC COOLING TOWERS, INC.					