

ITEM	PARTS	MATERIAL
1	MOTOR (7.5KW 4P)	
2	FAN	AL Alloy
3	TOP FRAME	HOT DIP GALV
4	DIFFUSION DECK	PP
5	FILLER	PVC
6	MILD LEVEL STAND	HOT DIP GALV
7	BASIN	FRP
8	TOWER SUPPORT	HOT DIP GALV
9	DISTRIBUTION TRAY	FRP
10	DISTRIBUTION TRAY CAP	FRP
11	FAN GUARD	HOT DIP GALV
12	MOTOR SUPPORT	HOT DIP GALV
13	BELT GUARD	FRP
14	LADDER	HOT DIP GALV
15	SUMP TANK	FRP
16	PANEL	FRP
17	FAN STACK	FRP

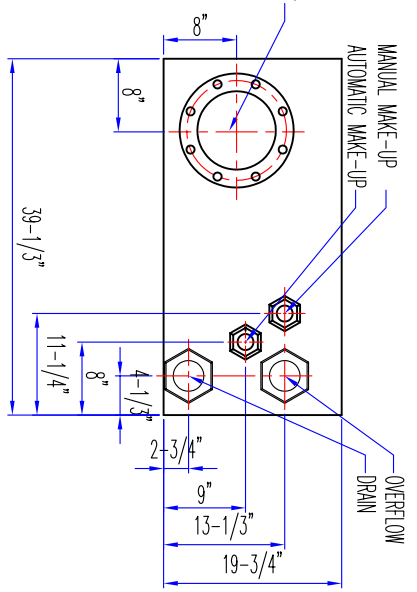
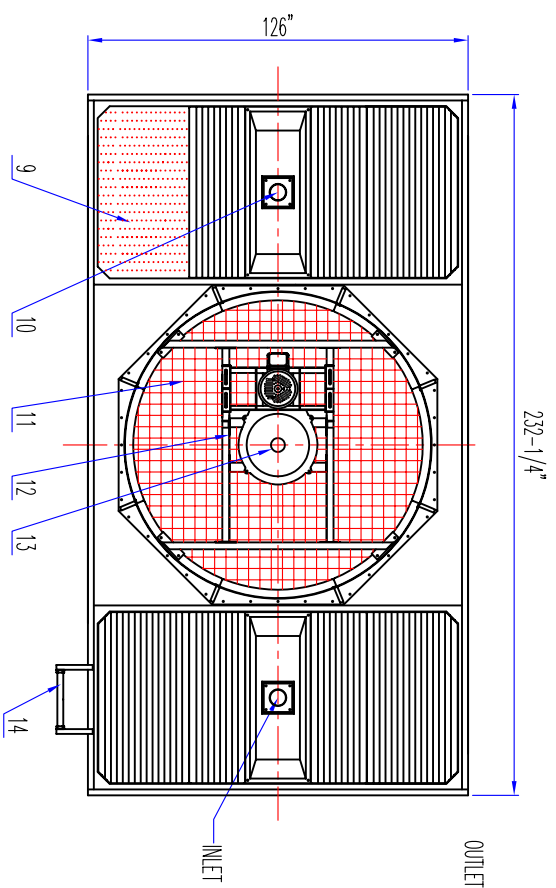

ITEM	SPECIFICATION	QTY
INLET	ø6"	2
OUTLET	ø8"(FLANGE)	1
AUTOMATIC MAKE-UP	ø1-1/2" (ABS SOCKET)	1
MANUAL MAKE-UP	ø1-1/2" (ABS SOCKET)	1
OVERFLOW	ø3" (ABS SOCKET)	1
DRAIN	ø3" (ABS SOCKET)	1

MOREL	MOTOR
FMS-300-7.5	7.5KW/4P
FMS-300-11	11KW/4P
FMS-300-15	15KW/4P

NOTE:
1. CONTINUING ENGINEERING RESEARCH RESULTS IN STEADY IMPROVEMENTS. THEREFORE, THESE SPECIFICATIONS AND DATA ARE SUBJECT TO CHANGE WITHOUT NOTICE. CONSULT WITH FACTORY FOR CURRENT CERTIFIED DIMENSIONS.

APPROVED	KM LIN	06-26-2007	DWG TITLE:	OVERALL DIMENSION
CHECKED	NOJIN	11.08.2007	DWG DETAIL:	FMS-300
DRAWN	HUANG	06-26-2007	DWG NO.	ADMS-0300-P0
			SCALE	1:60

PROTEC COOLING TOWERS, INC.